

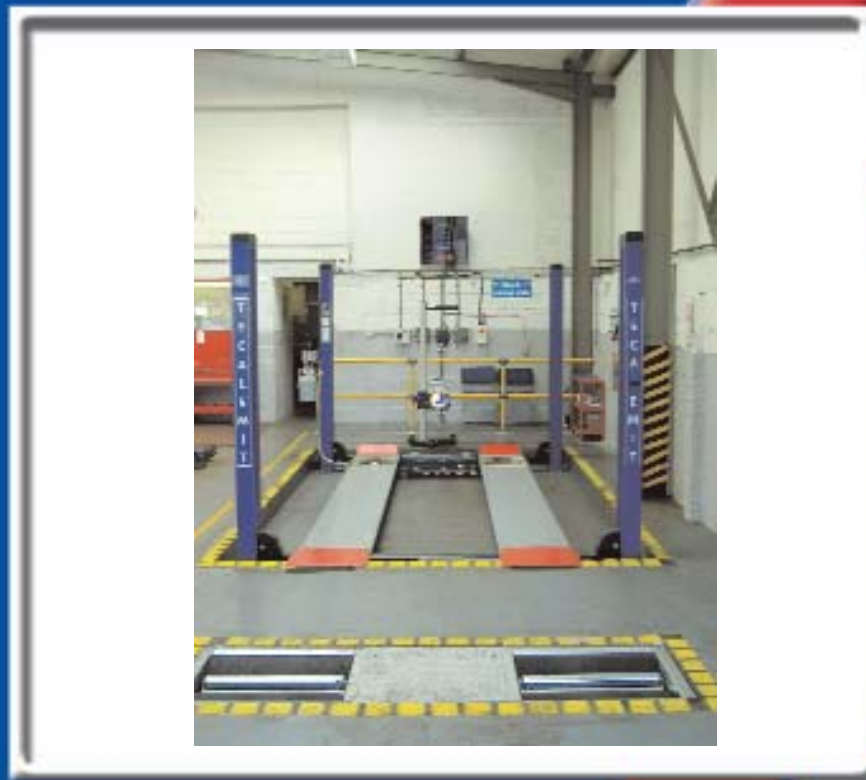

Saracen Distribution
Unit 9, Grandstand Business Centre
Faraday Road, Hereford, HR4 9NS
Tel No: 01432 344133
Fax No: 01432 34412
Mobile: 07836 756468
info@saracendistribution.co.uk
<http://www.saracendistribution.co.uk>

QUADRA 3.5T CLASS IV MOT LIFT with recess for turning plates

SF 9004



KEY FEATURES

- Electro hydraulic Operation
- Suitable for Class IV MOT Testing
- Platform Design for recessed turning plates

INSTALLATION & APPLICATION

The SF9004 lift is suitable for Class IV MOT testing. The lift incorporates recess in the platform for flush fitting capitive turning plates to be fitted. The lift is supplied with plates which cover the platform recesses should the turning plate option not be purchased.

When installed, the flush fitting turning plates allow for easy vehicle movement and positioning. The SF 9004 cannot be upgraded for use in ATL or Single Man Test lanes.

Installation

The floor onto which the lift is to be installed should be a level +/- <8mm. The concrete pad onto which the columns are secured should be constructed of C30 concrete

160mm thick, excluding the thickness of any screed or paving that may be added.

If in doubt a qualified person (structural engineer) should be consulted. For lifts requiring a 3Ph power supply (400V, 2.2Kw) there should be a fused circuit protection. Should lighting kits or other accessories be required a neutral conductor should be provided.

Recommended Jacking Beams

Tecalemit recommends the following jacking beam with the Quadra Service lift:

Description	Part No
1.8t capacity manually operated Jacking Beam	SS 8748

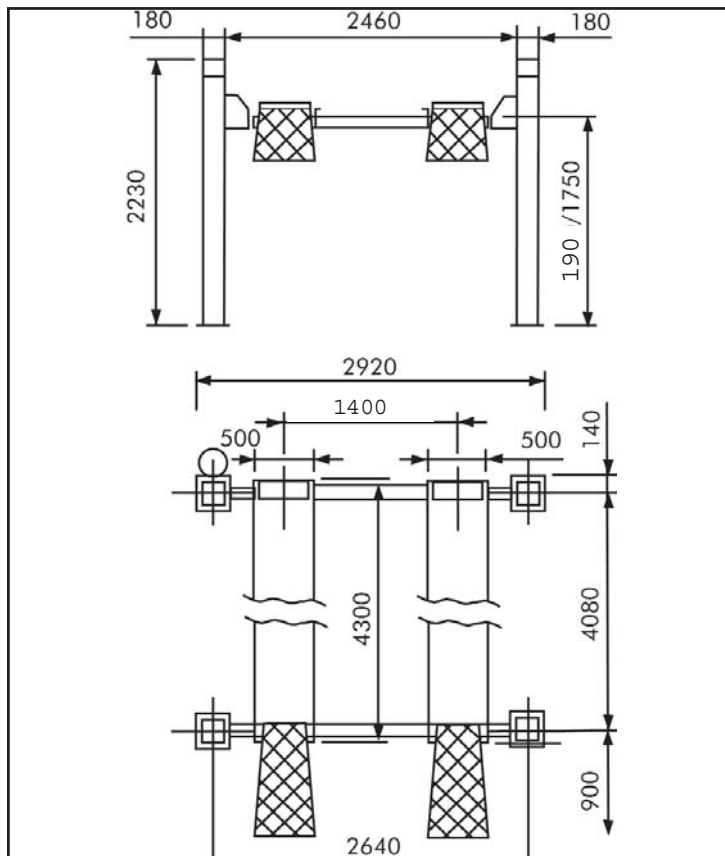

PART NO & ORDERING INFORMATION

Description	Part No
Quadra 3.5t Class IV MOT Lift 3Ph Surface Mounted	SF 9004
Quadra 3.5t Class IV MOT Lift 1Ph Surface Mounted	SF 9004/1
Quadra 3.5t Class IV MOT Lift 3Ph For Recessed Installation	SF 9004/Rec
Quadra 3.5t Class IV MOT Lift 1Ph For Recessed Installation	SF 9004/Rec/1

TECHNICAL SPECIFICATIONS & DIMENSIONS

Maximum Load	3500Kg
Maximum Platform height	1750mm
Maximum Lifting Time	50 sec
Lowering Time	45 sec
Power Supply 3Ph	400V, 50Hz, 3Ph N&E
Power Supply 1Ph	230V, 50Hz
Motor	2.2Kw
Fused Isolator Rating 3Ph	15A
Fused Isolator Rating 1Ph	30A

OPTIONS & ACCESSORIES

Description	Part No
1.8t Capacity Hydraulic Jacking Beam	SS 8748
4 Tube lighting kit	OA 60342
Drive Through Kit for Surface Mounted lifts	OA 60344
Drive Through Kit for Recessed installations	OA 60334
Ball Bearing Tyre Radius Turning Plate	OA 60292

SERVICE

Tecalemit have a team of over 50 service engineers covering the whole of the UK. On-site maintenance, testing, re-calibration and trouble-shooting can all be carried out with the minimum of fuss and downtime for customers. Please consult our Plymouth Service Centre for further information on 01752 219100.

WARRANTY

All products carry a 12 month warranty from the date of supply/installation, installation to be carried out by Tecalemit engineers. Exceptions to this being electrical cables and consumables.

SALES

Tecalemit Garage Equipment Co Ltd, Eagle Road, Langage Business Park, Plympton, Plymouth, Devon PL7 5JY

Tel: 00 44 (0) 1752 219111
 Fax: 00 44 (0) 1752 219128
 Email: sales@tecalemmit.co.uk
 Web: www.tecalemit.co.uk

