



Saracen Distribution  
Unit 9, Grandstand Business Centre  
Faraday Road, Hereford, HR4 9NS  
Tel No: 01432 344133  
Fax No: 01432 34412  
Mobile: 07836 756468  
info@saracendistribution.co.uk  
http://www.saracendistribution.co.uk

# POLARIS AUTOMATIC TYRE CHANGER

## AL 520



### KEY FEATURES

- Pneumatic high pressure bead breaker
- Precision pneumatic locking device for operating arm
- Tilting column for improved accessibility
- Improved clamping system
- 2 speed turntable operates in 2 directions of rotation

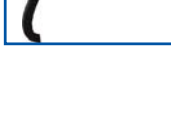

### INSTALLATION & APPLICATION

The AL 520 is an automatic tyre changer with tilting column. The key feature is the pneumatic locking system which ensures total stability of the operating head thus ensuring that there is no contact between operating tool and wheel rim. The AL 520 has the option of an integral tubeless inflation system as opposed to our external 'add on' system. The integral inflation system sends a high pressure air blast via the clamping jaws directly into the tyre.

The AL 520 requires a 3Ph power supply and should be installed in a position that allows sufficient space for movement of the tilting column. The AL 520 is also supplied complete with an alloy rim protection kit.

### TECHNICAL SPECIFICATIONS & DIMENSIONS

Net Weight	206Kg
Electrical Motor	(1.7Hp) 2 speed
Power Supply	400V 3Ph
Operating Pressure	8 - 12 Bar
Bead Breaker	2500Kg
Max. Rim Diameter	10" - 23"
Max. Wheel Diameter	1000mm
Max. Wheel Width	3" - 12"

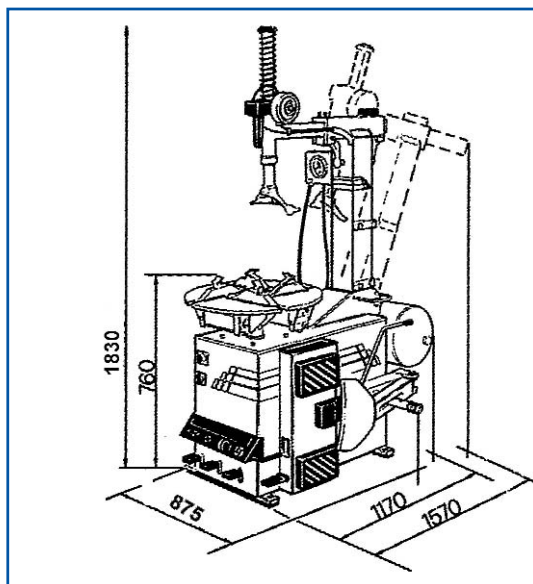

### PART NO & ORDERING INFORMATION

Polaris Automatic Tyre Changer 3Ph	AL 520
Polaris Automatic Tyre Changer 3Ph with integrated Tubeless Tyre Inflation System	AL 520IT

### OPTIONS & ACCESSORIES

Description	Part No
1. Alloy Rim Protection Kit - comprising jaw and head protection complete with protected bead lifter	OA 60038
2. Motorcycle Wheel Jaw Extensions	OA 60039
3. 8" Wheel Set suitable for motorised horticultural and golfing vehicles	OA 60048
4. Technoroller SL For use with Alloy & Wide wheels (Includes OA 60104)	OA 60252
5. Technoroller SL Pax: Suitable for fitting PAX Tyres, Wide & Racing wheels, includes Centre Post, Levers & Reglettes	OA 60260
To upgrade Technoroller SL for Pax use -	
6. Pax Kit comprises Rollers, adaptors, Levers & Reglettes	OA 60077
7. Patented Anti-Ejection System that ensures maximum safety for operators during tyre inflation	OA 60060
8. Zeppa EMT Tyre Fitting Device (36.2mm)	OA 60102
8. Zeppa EMT Tyre Fitting Device (69mm) for racing tyre wheels	OA 60103
9. Airline Tyre inflator	SP 8528
10. Spiral Air Hose for use with SP 8528. 30ft (9.1m) coiled nylon tubing 1/4" BSP fittings, male/male connectors	OA 9760
11. Tubeless Inflator for Tyre Safety Cage	OA 60142
12. Power Arm for Technoroller SL (Not shown)	OA 60267
13. Tubeless Tyre Inflation Kit	OA 60283

#### SERVICE

Tecalemit have a team of over 50 service engineers covering the whole of the UK. On-site maintenance, testing, re-calibration and trouble-shooting can all be carried out with the minimum of fuss and downtime for customers. Please consult our Plymouth Service Centre for further information on 01752 219100.

#### WARRANTY

All products carry a 12 month warranty from the date of supply/installation, installation to be carried out by Tecalemit engineers. Exceptions to this being electrical cables and consumables.

#### SALES

Tecalemit Garage Equipment Co Ltd, Eagle Road, Langage Business Park, Plympton, Plymouth, Devon PL7 5JY

Tel: 00 44 (0) 1752 219111  
 Fax: 00 44 (0) 1752 219128  
 Email: sales@tecalemmit.co.uk  
 Web: www.tecalemmit.co.uk

