



Saracen Distribution
Unit 9, Grandstand Business Centre
Faraday Road, Hereford, HR4 9NS
Tel No: 01432 344133
Fax No: 01432 34412
Mobile: 07836 756468
info@saracendistribution.co.uk
http://www.saracendistribution.co.uk

POLARIS AUTOMATIC TYRE CHANGER

AL 720IT RACING



KEY FEATURES

- Automatic Positioning of operating arm
- Precision pneumatic locking device for operating arm
- Tilting column for improved accessibility
- 2 Speed 2 direction turntable
- Automated extendable operating column to accommodate very wide wheels
- Integral inflation system



AUTOMATIC TYRE CHANGER

AL 720IT RACING



INSTALLATION & APPLICATION

The AL 720 IT Racing is a fully automatic tyre changer with tilting /extending column. Developed specifically for use with extra wide and large diameter wheels.

Key features include the extending column to allow access for the widest wheels, our unique pneumatic clamping system which ensures total stability of the operating arm. Automatic positioning of the operating head via a twist grip control on the column, 2 speed and 2 directional turntable and integral tubeless inflation system.

The AL 720 IT Racing requires a 3Ph power supply and should be installed in a position that allows sufficient space for movement of the tilting column. The AL 720IT Racing is also supplied complete with an alloy rim protection kit.

TECHNICAL SPECIFICATIONS & DIMENSIONS

Net Weight	217Kg
Electrical Motor	(1.7Hp) 2 speed
Power Supply	400V 3Ph
Operating Pressure	8 - 12 Bar
Bead Breaker	2500Kg
Max. Rim Diameter	10" - 23"
Max. Wheel Diameter	1000mm
Max. Wheel Width	3" - 16"

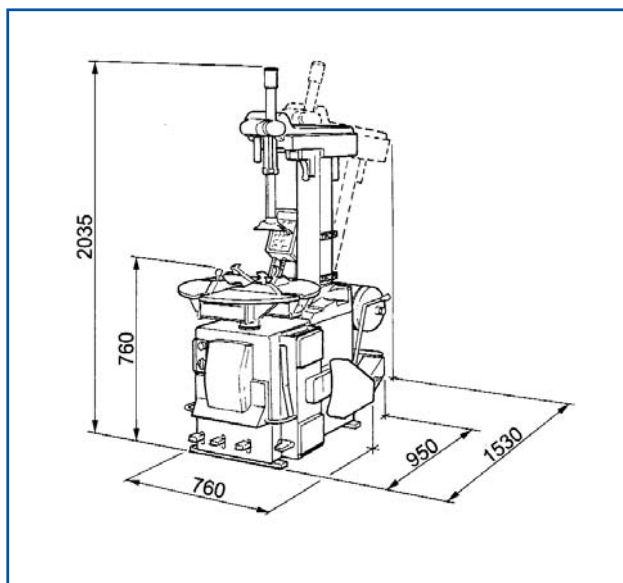

PART NO & ORDERING INFORMATION

Polaris Fully Automatic Tyre Changer 3Ph

AL 720IT Racing

OPTIONS & ACCESSORIES

1. Alloy Rim Protection Kit - comprising jaw and head protection complete with protected bead lifter	OA 60038
2. Motorcycle Wheel Jaw Extensions	OA 60039
3. 8" Wheel Set suitable for motorised horticultural and golfing vehicles	OA 60048
4. Technoroller SL suitable for fitting to all car tyre changers except BL512	OA 60252
5. Patented Anti-Ejection System that ensures maximum safety for operators during tyre inflation	OA 60060
6. Zeppa EMT Tyre Fitting Device (36.2mm)	OA 60102
6. Zeppa EMT Tyre Fitting Device (69mm)	OA 60103
7. Airline Tyre inflator	SP 8528
8. Spiral Air Hose for use with SP 8528. 30ft (9.1m) coiled nylon tubing 1/4" BSP fittings, male/male connectors	OA 9760
9. Wheel Removal Trolley	OA 60148
10. Technoroller SL Pax: Suitable for fitting to all car tyre changers except BL512. Required for fitting on PAX tyres	OA 60260
11. Power Arm for Technoroller SL (Not shown)	OA 60267
12. Tubeless Tyre Inflation Kit (Not shown)	OA 60283

SERVICE

Tecalemit have a team of over 50 service engineers covering the whole of the UK. On-site maintenance, testing, re-calibration and trouble-shooting can all be carried out with the minimum of fuss and downtime for customers. Please consult our Plymouth Service Centre for further information on 01752 219100.

WARRANTY

All products carry a 12 month warranty from the date of supply/installation, installation to be carried out by Tecalemit engineers. Exceptions to this being electrical cables and consumables.

SALES

Tecalemit Garage Equipment Co Ltd, Eagle Road, Langage Business Park, Plympton, Plymouth, Devon PL7 5JY

Tel: 00 44 (0) 1752 219111
Fax: 00 44 (0) 1752 219128
Email: sales@tecalemmit.co.uk
Web: www.tecalemmit.co.uk

