



Saracen Distribution  
Unit 9, Grandstand Business Centre  
Faraday Road, Hereford, HR4 9NS  
Tel No: 01432 344133  
Fax No: 01432 34412  
Mobile: 07836 756468  
info@saracendistribution.co.uk  
<http://www.saracendistribution.co.uk>

# POLARIS SEMI AUTOMATIC TYRE CHANGER

## BL 512



### KEY FEATURES

- Compact arm takes up the least possible space in the workshop
- Special structure of the column provides extra strength
- Designed to handle a wide range of tyres
- Self - centering device on mobile tracks
- Design of the tower allows the mounting & demounting of even the most problematic tyres, operating head includes a central hole allowing the insertion of a bead lever to facilitate the mounting of low profile tyres



## INSTALLATION & APPLICATION

The BL512 Swing arm tyre changer is a heavy-duty semi-automatic tyre changer suitable for use with most standard car wheels. The new Turntable & Bead Breaker design allows for easier removal of wider tyres. Supplied complete with 1Kg Bead Paste.

BL 512 is supplied complete with an alloy rim protection kit and requires a 1Ph power supply.

## TECHNICAL SPECIFICATIONS & DIMENSIONS

Net Weight	184Kg
Electrical Motor	0.75Hp
Power Supply	240V 1Ph
Operating Pressure	8 - 12 Bar
Bead Breaker	2500Kg
Max. Rim Diameter	10" - 22"
Max. Wheel Diameter	1000mm
Max. Wheel Width	3" - 12"

\*Please note that the Technoroller options **cannot** be fitted to this tyre changer

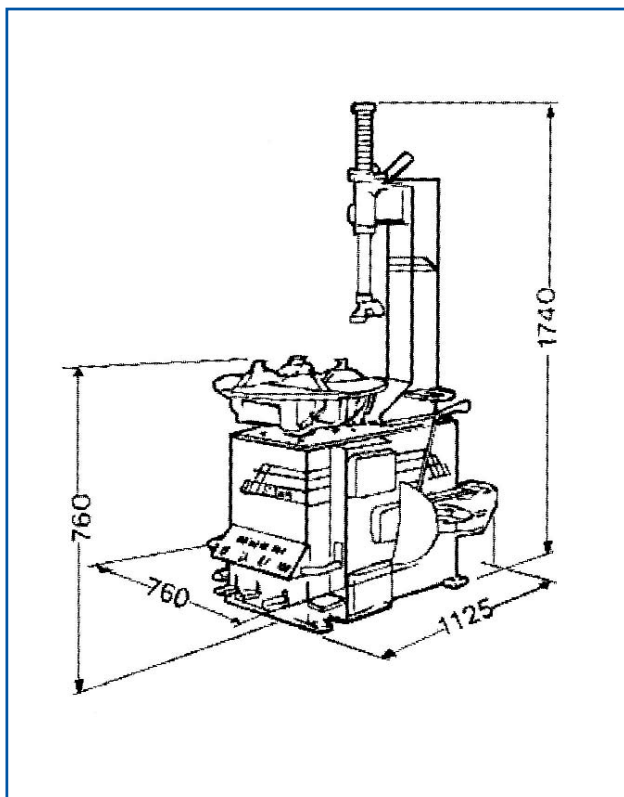

## PART NO & ORDERING INFORMATION

Polaris Semi Automatic Tyre Changer 1Ph

BL 512

## OPTIONS & ACCESSORIES

Description	Part No
1. Alloy Rim Protection Kit - comprising jaw head & tyre lever protection	OA 60038
2. Motorcycle Wheel Jaw Extensions	OA 60039
3. 8" Wheel Set suitable for motorised horticultural and golfing vehicles	OA 60048
4. Patented Anti-Ejection System that ensures maximum safety for operators during tyre inflation	OA 60060
5. Tyre Mounting Tool for Swing Arm Tyre Changers - assists in removal of wide tyres (BL 512) only	OA 60163
6. Zeppa EMT Tyre Fitting Device (36.2mm)	OA 60102
6. Zeppa EMT Tyre Fitting Device (69mm) (for Racing Tyre Wheels)	OA 60103
7. Airline Tyre inflator	SP 8528
8. Spiral Air Hose for use with SP 8528. 30ft (9.1m) coiled nylon tubing 1/4" BSP fittings, male/male connectors	OA 9760
9. Wheel Removal Trolley	OA 60148
10. Tubeless Tyre Inflation Kit	OA 60283
11. Bead Paste 1Kg	TT 5931851
12. Tyre Valve Starter Pack (Pack of 100 Tyre Valves)	TT 2122395

### SERVICE

Tecalemit have a team of over 50 service engineers covering the whole of the UK. On-site maintenance, testing, re-calibration and trouble-shooting can all be carried out with the minimum of fuss and downtime for customers. Please consult our Plymouth Service Centre for further information on 01752 219100.

### WARRANTY

All products carry a 12 month warranty from the date of supply/installation, installation to be carried out by Tecalemit engineers. Exceptions to this being electrical cables and consumables.

### SALES

Tecalemit Garage Equipment Co Ltd, Eagle Road, Langage Business Park, Plympton, Plymouth, Devon PL7 5JY

Tel: 00 44 (0) 1752 219111  
 Fax: 00 44 (0) 1752 219128  
 Email: sales@tecalemmit.co.uk  
 Web: www.tecalemmit.co.uk

