



Saracen Distribution
Unit 9, Grandstand Business Centre
Faraday Road, Hereford, HR4 9NS
Tel No: 01432 344133
Fax No: 01432 34412
Mobile: 07836 756468
info@saracendistribution.co.uk
<http://www.saracendistribution.co.uk>

POLARIS ARTICULATED ARM TYRE CHANGER

ML 450



KEY FEATURES

- Nylon / Plastic mounting head suitable for alloy rims
- Fixed pole with articulated operating arm
- Heavy duty turntable
- Suitable for all types of wheel
- Ideal entry level machine
- Self - centering device on mobile tracks

INSTALLATION & APPLICATION

The Polaris ML 450 Tyre Changer is the entry-level product to the Tecalemit tyre changer range. The ML 450 combines the robust chassis, turntable and bead breaker of more advanced models and utilises the versatile articulated arm design which is ideal for use with alloy wheel rims in particular. The nylon operating head of the tyre changer is designed to work in contact with the wheel rim and eliminates the possibility of damage to the rim.

TECHNICAL SPECIFICATIONS & DIMENSIONS

Net Weight	165Kg
Electrical Motor	0.75Hp
Power Supply	240V 1Ph
Operating Pressure	8 - 12 Bar
Bead Breaker	2500Kg
Max. Rim Diameter	10" - 22"
Max. Wheel Diameter	1000mm
Max. Wheel Width	3" - 12"

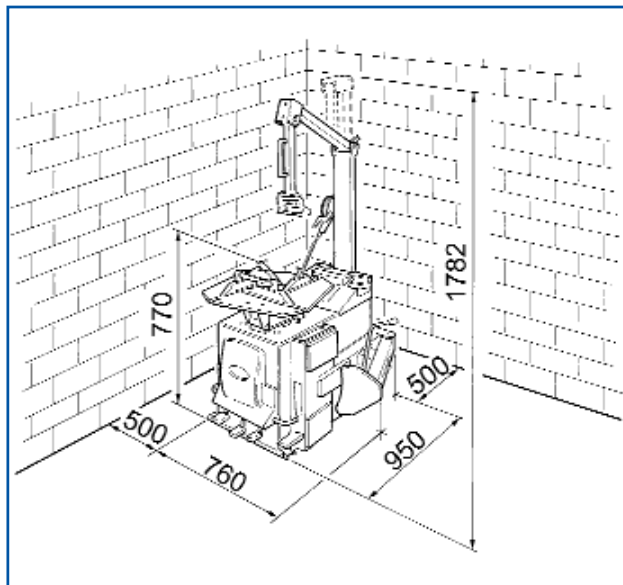

PART NO & ORDERING INFORMATION

Polaris Tyre Changer 1Ph

ML 450

OPTIONS & ACCESSORIES

Description	Part No
1. Alloy Rim Protection Kit - comprising jaw and head protection complete with protected bead lifter	OA 60038
2. Motorcycle Wheel Jaw Extensions	OA 60039
3. 8" Wheel Set suitable for motorised horticultural and golfing vehicles	OA 60048
4. Technoroller SL suitable for fitting to all car tyre changers except BL512	OA 60252
5. Patented Anti-Ejection System that ensures maximum safety for operators during tyre inflation	OA 60060
6. Tyre Mounting Tool for Swing Arm Tyre Changers - assists in removal of wide tyres (BL 512) only	OA 60163
7. Pax Kit for AF 1720 machines comprises adaptors & levers	OA 60077
8. Zeppa EMT Tyre Fitting Device (36.2mm)	OA 60102
8. Zeppa EMT Tyre Fitting Device (69mm)	OA 60103
9. Airline Tyre inflator	SP 8528
10. Spiral Air Hose for use with SP 8528. 30ft (9.1m) coiled nylon tubing 1/4" BSP fittings, male/male connectors	OA 9760
11. Digital Manometer for Tyre Safety Cage	OA 60139
12. Tubeless Inflator for Tyre Safety Cage	OA 60142
13. Technoroller SL Pax: Suitable for fitting to all car tyre changers except BL512. Required for fitting on PAX tyres	OA 60260
14. Power Arm for Technoroller SL (Not shown)	OA 60267
15. Tubeless Tyre Inflation Kit (Not shown)	OA 60283

SERVICE

Tecalemit have a team of over 50 service engineers covering the whole of the UK. On-site maintenance, testing, re-calibration and trouble-shooting can all be carried out with the minimum of fuss and downtime for customers. Please consult our Plymouth Service Centre for further information on 01752 219100.

WARRANTY

All products carry a 12 month warranty from the date of supply/installation, installation to be carried out by Tecalemit engineers. Exceptions to this being electrical cables and consumables.

SALES

Tecalemit Garage Equipment Co Ltd, Eagle Road, Langage Business Park, Plympton, Plymouth, Devon PL7 5JY

Tel: 00 44 (0) 1752 219111
 Fax: 00 44 (0) 1752 219128
 Email: sales@tecalemmit.co.uk
 Web: www.tecalemmit.co.uk

